

MECHANICAL JACKS

CJ Series - Rack Jacks

SIMPLEX



CJ15 & CJ100 Shown

Capacity Range▶ 1.65 - 11.13 tons

Stroke Range.....▶ 13.78 in.

Minimum Height Range▶ 28.54 in.

- ▶ Developed in accordance with the latest safety regulations.
- ▶ Suitable for lifting loads of any type.
- ▶ The jack is rated for full capacity at both the head and toe lifts.
- ▶ Lifting with either fixed toe or on clawed head.
- ▶ Low expenditure of force through optimal ratio.

FOLDING HANDLE

Safety crank with folding handle.



CE COMPLIANT

Our Jack design specifications meet or exceed ANSI /ASME B30.1 Safety Standards.

Mechanical Jacks

Here a CJ100 is used to position this cargo container for repair. Its solid base provides greater stability and more surface area.▼

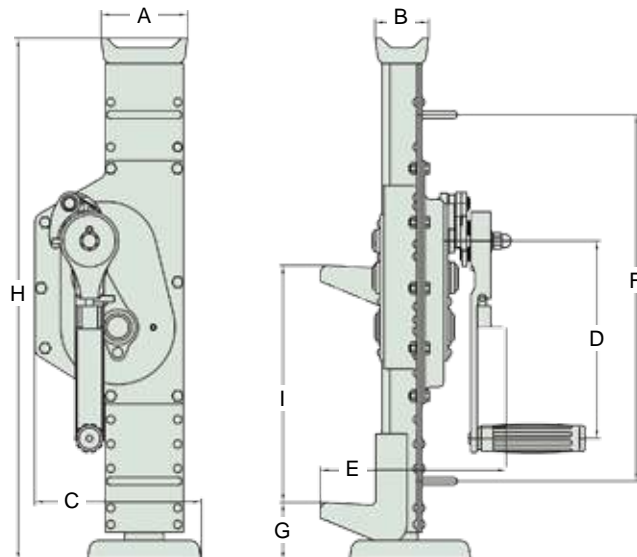

Model	Head/Toe Capacity (tons)	Dimensions (in)									Weight (lbs)
		A	B	C	D	E	F	G	H	I	
		Width	Depth	Width	Length	Depth	Length	Height	Minimum Height	Stroke	
CJ15	1.65	3.54	1.97	5.94	9.84	7.95	20.67	2.56	28.54	13.78	29.76
CJ30	3.31	3.94	1.97	8.03	9.84	8.39	20.67	2.76	28.54	13.78	48.50
CJ50	5.51	4.33	2.68	8.31	9.84	9.29	20.67	2.76	28.54	13.78	61.72
CJ100	11.13	5.51	2.76	10.12	11.81	11.69	23.23	3.15	31.50	13.78	101.41