

## Characteristics of MAX DYNAMIC® Coupling

1. Facility protection for swirl and twist, impact and abrasion
2. Very simple replacement and maintenance without and grease
3. Very simple replacement without the separation of motor or connector on the related line due to it's simple structure
4. Possible for the dissimilar connection and assembling with same hub
5. Polyurethane based for having good water resistance, chemical resistance
6. Highest flexible elasticity on run
7. Less noise



## Application

- Agitator
- Blower
- Compressor
- Conveyors
- Cranes and Hoists
- Elevators
- Fans
- Generators
- Pump
- Brewery and Distilling
- Food Industry
- Lumber Industry
- Pulp and Paper Mill
- Rubber Industry
- Steel Industry
- Textile Mills
- Aggregate Processing
- Cement

## MAX DYNAMIC® Standard Coupling

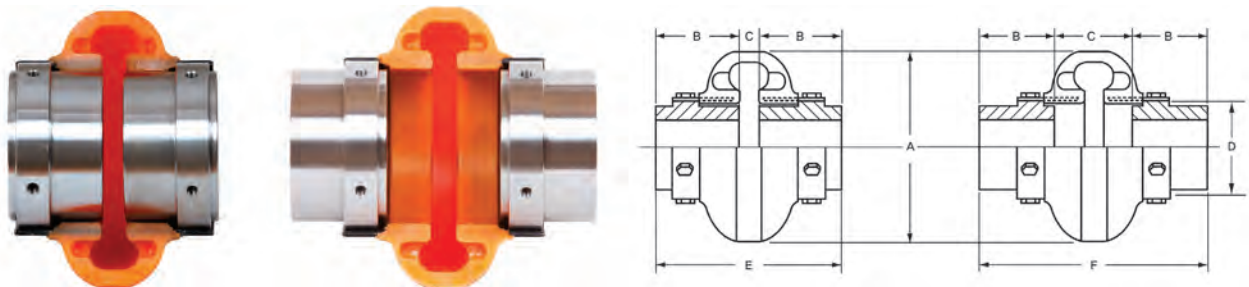

Max Dynamic Coupling No.	Torque (kgf.m)	Max. Bore (mm)	Max. rpm	Power Rating (kw/rpm)	Dimensions (mm)							
					A	B	C		D	E		F
					Out Dia	Hub Length	Min. Shaft Spacing	Max. Shaft Spacing	Hub Dia	Total Length		
									In	Out		
D-2	2.20	28	7,500	0.0023	89	24	35	47	47	83	95	
D-3	4.20	34	7,500	0.0043	102	32	9	47	59	83	111	
D-4	6.40	42	7,500	0.0066	116	37	9	47	66	83	121	
D-5	11.00	48	7,500	0.0110	137	45	10	52	80	100	142	
D-10	16.70	55	7,500	0.0170	162	45	11	53	93	101	143	
D-20	26.70	60	6,600	0.0270	184	50	15	63	114	115	163	
D-30	42.10	75	5,800	0.0430	210	56	12	68	138	124	180	
D-40	63.40	85	5,000	0.0660	241	61	12	74	168	134	196	
D-50	88.20	90	4,200	0.0900	279	69	12	86	207	150	224	
D-60	144.00	105	3,800	0.1480	318	80	11	99	222	171	259	
D-70	254.00	120	3,600	0.2620	356	85	18	109	235	189	281	
D-80	455.00	155	2,000	0.4670	406	114	17	149	286	245	377	
D-100	980.00	171	1,900	1.0000	533	140	44	95	359	324	375	
D-120	1,961.00	190	1,800	2.0000	635	152	57	124	448	362	429	

# MAX DYNAMIC<sup>®</sup> Standard Coupling with Compression Bushed Hubs



"Australia's Only Genuine Wholesaler"

Finer Power Transmissions P/L | www.finerpt.com

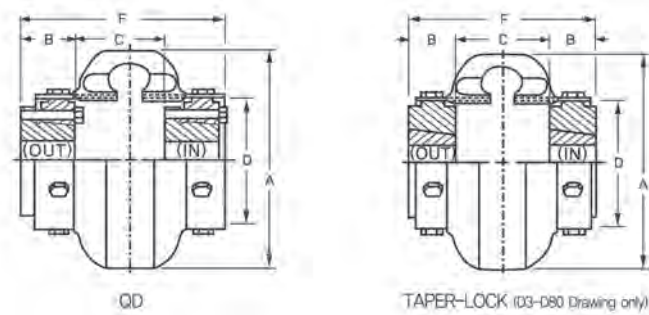

## Specification Data with QD Hubs

Max Dynamic Coupling No.	QD Bush No.	Torque (kgf.m)	Max. Bore (mm)	Max. rpm	Power Rating (kw/rpm)	Dimensions (mm)						Weight (kg)	
						A	B	C		D	E		F
						Out Dia	Hub Length	In	Out	Hub Dia	Total Length		
											In		Out
D-4	JA	6.4	30	7,500	0.0066	116	25	31	48	66	82	99	0.95
D-5	SH	11.0	35	7,500	0.0110	137	32	44	48	80	108	114	1.63
D-10	SDS	16.7	42	7,500	0.0170	162	33	30	59	93	97	125	2.18
D-20	SK	26.7	55	6,600	0.0270	184	48	16	67	114	108	162	3.86
D-30	SF	42.1	60	5,800	0.0430	210	51	37	56	138	138	157	6.35
D-40	E	63.4	75	5,000	0.0660	241	67	32	44	168	165	178	10.80
D-50	E	88.2	75	4,200	0.0900	279	67	35	73	207	168	207	17.06
D-60	F	144.0	90	3,800	0.1480	318	92	38	48	222	222	232	20.64
D-70	J	254.0	100	3,600	0.2620	356	114	33	36	235	262	265	30.89
D-80	M	455.0	140	2,000	0.4670	406	171	19	32	286	362	375	63.50
D-100	M	980.0	140	1,900	1.0000	533	173	44	29	359	390	375	113.40
D-120	N	1,961.0	150	1,800	2.0000	635	206	44	29	448	456	441	215.46

\* Note: Dimensions may vary depending on bushing manufacturer. Dimensions subject to change.

## Specification Data with Taper-Lock Hubs

Max Dynamic Coupling No.	Taper Lock Bush No.	Torque (kgf.m)	Max. Bore (mm)	Max. rpm	Power Rating (kw/rpm)	Dimensions (mm)						Weight (kg)	
						A	B	C		D	E		F
						Out Dia	Hub Length	In	Hub Dia	Total Length			
										In	Out		
D-3	1008	4.2	25	7,500	0.0043	102	22	43.0		59	87		0.82
D-4	1008	6.4	25	7,500	0.0066	116	22	43.0		66	87		1.18
D-5	1108	11.0	28	7,500	0.0110	137	22	56.0		80	100		1.81
D-10	1610	16.7	35	7,500	0.0170	162	25	52.0		93	103		2.72
D-20	1610	26.7	42	6,600	0.0270	184	25	63.5		114	114		4.08
D-30	2012	42.1	50	5,800	0.0430	210	32	65.0		138	129		6.17
D-40	2517	63.4	65	5,000	0.0660	241	44	60.0		168	149		9.89
D-50	2517	88.2	65	4,200	0.0900	279	44	76.0		207	165		14.29
D-60	3020	144.0	75	3,800	0.1480	318	51	84.0		222	186		21.14
D-70	3535	254.0	100	3,600	0.2620	356	89	60.0		235	238		30.25
D-80	4040	455.0	100	2,000	0.4670	406	102	95.0		286	298		37.19
								In	Out		In	Out	
D-100	4545	980.0	110	1,900	1.0000	533	114	38	152	359	267	381	113.40
D-120	5050	1,961.0	125	1,800	2.0000	635	127	51	181	448	305	435	185.07

Couplings

"Why compete against your supplier when you can be our partner"

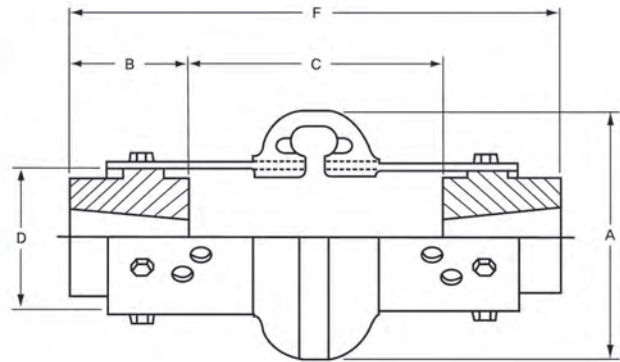

Max Dynamic Coupling No.	Torque (kgf.m)	Max. Bore (mm)	Max. rpm	Power Rating (kw/rpm)	Dimensions (mm)							
					A	B	C		D	E		F
					Out Dia	Hub Length	Min. Shaft Spacing	Max. Shaft Spacing	Hub Dia	Total Length		
									In	Out		
DS-2	2.20	28	7,500	0.0023	89	24	91	100	47	146	149	
DS-3	4.20	34	7,500	0.0043	102	37	85	140	59	184	216	
DS-4	6.40	42	7,500	0.0066	116	37	85	140	66	184	216	
DS-5	11.00	48	7,500	0.0110	137	45	89	140	80	184	228	
DS-10	16.70	55	7,500	0.0170	162	45	89	140	93	184	228	
DS-20	26.70	60	4,800	0.0270	184	50	67	180	114	238	280	
DS-30	42.10	75	4,200	0.0430	210	56	54	180	138	238	293	
DS-40	63.40	85	3,600	0.0660	241	61	41	180	168	238	307	
DS-50	88.20	90	3,100	0.0900	279	69	28	180	207	238	319	
DS-60	144.00	105	2,800	0.1480	318	80	66	250	222	318	415	
DS-70	254.00	120	2,600	0.2620	356	85	59	250	235	318	421	
DS-80	455.00	155	1,800	0.4670	406	114	37	250	286	318	478	

## Recommended Capscrew

Size	Torque (kgf.m)
D-2	2.3
D-3	
D-4	
D-5	
D-10	
D-20	4.1
D-30	
D-40	
D-50	
D-60	10.2
D-70	
D-80	
D-100	37.7
D-120	

### NOTE

1. A bolt having the highest tension shall be used
2. Locktite as adhesive shall be used
3. Never use a bolt more than twice

## The tolerance of installation

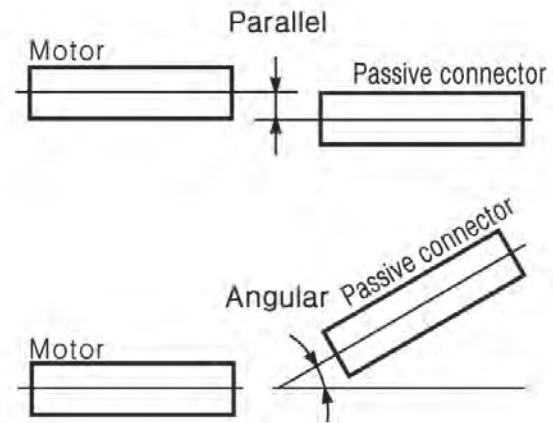
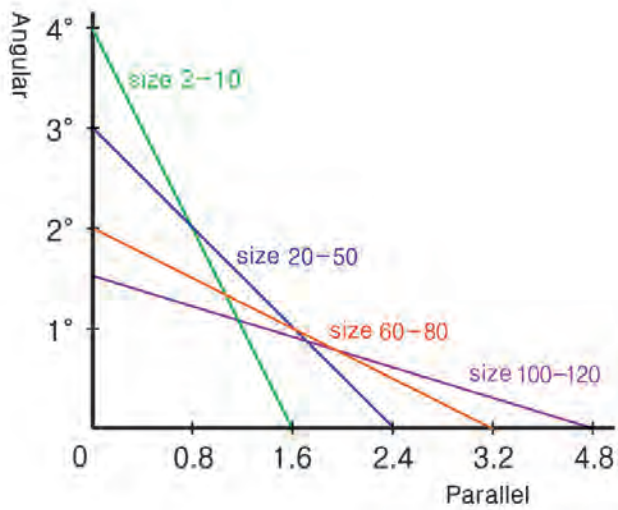

## The method of assembly

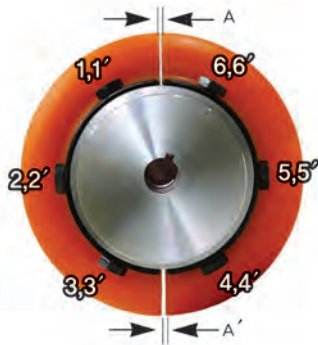

1. Adjust the face of A and A' at same space
2. Adjust Hub's Minimum space
3. Assemble the bolts in the order of 2-2'; 5-5'; 3-3'; 4-4'; 6-6'; 1-1'
4. Assemble the bolts in the middle part of the edge



1. Adjust the face of A and A' at same space
2. Adjust Hub's Minimum space
3. Assemble the bolts in the order of 2-2'; 7-7'; 3-3'; 6-6'; 1-1'; 4-4'; 8-8'; 5-5'
4. Assemble the bolts in the middle part of the edge

## Service (safety) factors for each running parts

General Application	Service Factor	Industry Application	Service Factor
Agitator	1.5	Aggregate Processing Cement	2.0~3.0
Blower	1.0~1.5	Brewery and Distilling	1.0~2.0
Compressor	1.0~2.0	Food Industry	1.0~2.0
Conveyor	1.25~1.5	Lumber Industry	1.5~2.5
Cranes and Hoist	2.0~2.5	Power Industry	1.0~2.5
Elevators	1.0~2.0	Pulp and Paper Mills	1.0~3.5
Fans	1.0~2.0	Rubber Industry	1.0~3.0
Generators	1.0~2.5	Steel Industry	2.0~4.5
Pumps	1.0~1.5	Textile	1.0~2.0

## Service/Safety Factor

Running Status		Service Factor
1	For being continuous running and light load weight	1.0
2	For being the various change of the rotary power	1.5
3	For being various and frequent variation on the turning force	2.0
4	For being the variation of the rotary power accompanying impact	2.5
5	For being high impact load-weight accompanying slight retro-rotation	3.0
6	For being frequent retro-rotation accompanying high impact	consult

