







HAND POWER PULLER

OPERATING INSTRUCTION

MULTI-FUNCTIONAL USES

 RECREATIONAL	 FRAMING	 INDUSTRIAL
 EMERGENCY	 FENCING	 STRAPPING

TO RELEASE TENSION:

Depress pawl spring in direction of arrow "A". Steadily push handle until drive pawl pushes and disengages stop pawl (not shown) to clear ratchet teeth. This releases load one notch. Repeat this handle motion as required to release tension a notch at a time.

CAUTION:

When releasing load avoid abrupt handle movements. Apply pressure to handle with an even and steady force.

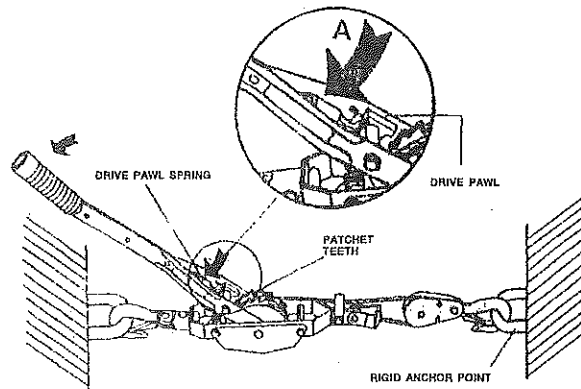

SPECIFICATION (BREAKING CAPACITY)						
CABLE	METHOD	1 TON	1-1/2 TON	2 TON	3 TON	4 TON
DOUBLE LINE	PULLING CAP.	1000KGS	1500KGS	2000 KGS	3000 KGS	4000 KGS
	Do not lift people or lift over people					
SINGLE LINE	PULLING CAP.	500 KGS	750 KGS	1000 KGS	1500 KGS	2000 KGS
	Do not lift people or lift over people					
CABLE DIAMETER		3/16" (5mm)	3/16" (5mm)	3/16" (5mm)	3/16" (5mm)	1/4" (6mm)
LEVERAGE		15:1	15:1	15:1	15:1	15:1

TO RAISE LOAD OR APPLY TENSION:

Engage drive pawl and ratchet wheel by pushing pawl spring in direction of arrow "A", and then raise the handle towards the direction of arrow "C". Each stroke of handle will wind cable to pull load.

TO EXTEND CABLE:

Secure hook and pulley to a rigid anchor. Depress drive pawl spring in direction of arrow "B". Raise handle and hold firmly towards the direction of arrow "E", then depress stop pawl in direction of arrow "D" and at the same time pull until desired slack is obtained.

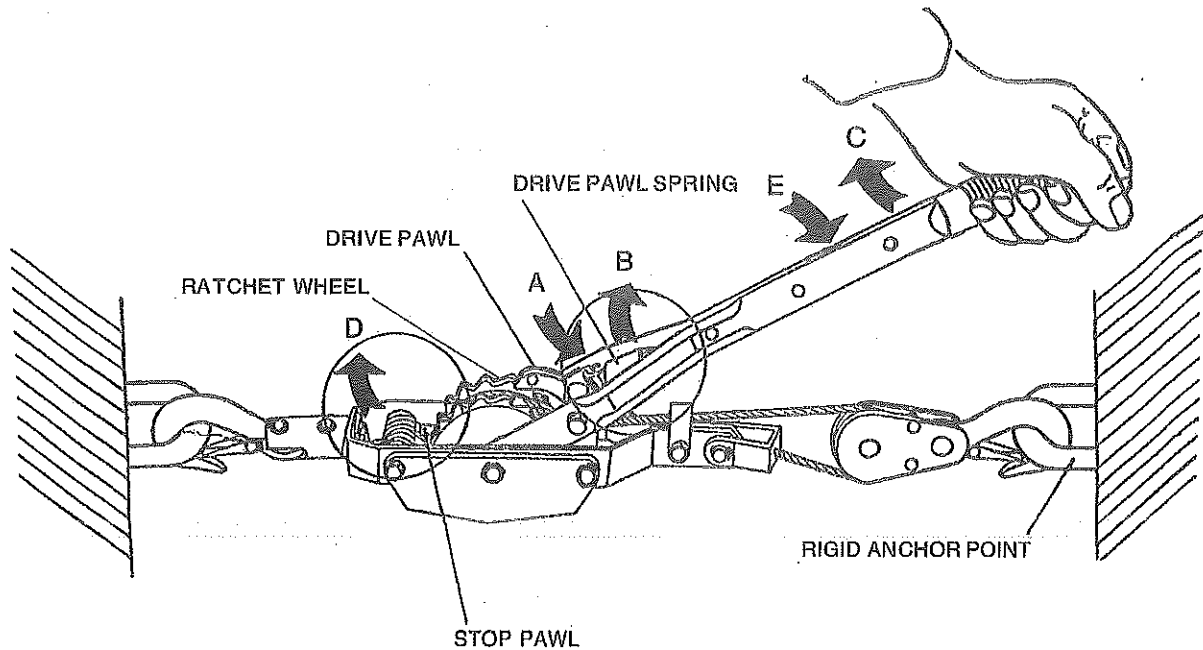

CAUTION: Make sure your Hand Power Puller is maintained in safe and proper working condition by observing the following rules:

1. Inspect cable regularly to examine the frays, kinks, broken strands or distortion. The cable should be replaced once one of above situation has occurred.
2. Do not pull cable over or around a corner.
3. Do not wrap cable around any object and hook it back on itself.
4. Do not overload; know how much load is allowed when you are pulling.
5. Do not use a "cheater" pipe or other device to engthen the handle for additional leverage. This will destroy the puller itself.
6. Do not operate puller with less than 3 wraps of cable on the spindie.
7. Please do use an adequate sling, eyebolt or other accessory attached to the load to be pulled. And make sure that there is positive engagement of the puller hook to the load.
8. Do not lift people or lift over people.

CABLE REPLACEMENT

A "keyhole" opening of special quick-change design in the barrel of the ratchet wheel and a swayed end to the cable permit instant, secure replacement of the cable. Pull all the cable off the ratchet wheel, snap old cable out of "keyhole", snap in new cable, and then rewind cable on ratchet wheel.