



LEVER BLOCK

INSTRUCTION MANUAL

Imported exclusively by Pacific Hoists Pty. Ltd. & Pacific Hoists Ltd.
In support of cancer charities in Australia & New Zealand



IMPORTANT

PLEASE READ THIS OPERATION MANUAL BEFORE USING THIS PRODUCT. THIS MANUAL CONTAINS IMPORTANT INFORMATION REGARDING SAFETY, OPERATION, INSTALLATION & MAINTENANCE.

ALWAYS OPERATE, INSPECT AND MAINTAIN THIS PRODUCT IN ACCORDANCE WITH AS1418.2

INTRODUCTION

Thank you for purchasing your new Challenger Lever Block. This manual lifting device now uses the latest technology to ensure you of a higher quality, robust design with a high level of operator safety which is easier and safer to use, ensuring a longer service life. Choosing the Challenger brand also directly supports cancer charities in Australia.

It is important that this manual be kept in a safe place where any operator of the Challenger Lever Block can refer to it and understand the operating principles of this device. All users of this Challenger Lever Block should read this manual in full and understand the safe operating principles of the device.

FEATURES

FEATURES OF THE CHALLENGER LEVER BLOCK INCLUDE THE FOLLOWING:

- Designed in accordance with European Standard EN13157 & AS1418.2
- Improved braking performance to ensure the integrity of the load under all conditions
- Design improvements result in 25% less operator effort to lift the rated load
- Safety of design has been prioritised to alleviate unexpected accidents
- New style load hooks with cast “notched” safety latches increase service life of the latches and improve the safety of the lifting operation
- Improved design of load sprockets for safer operation
- Key internal components are now CNC machined for improved overall product reliability
- All Challenger Lever Blocks are individually load tested in accordance with AS1418.2

A comprehensive range of spare parts is readily available.

SPECIFICATIONS

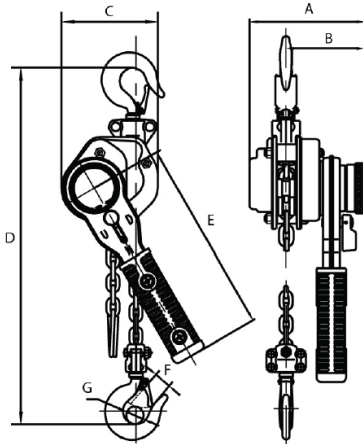

250KG

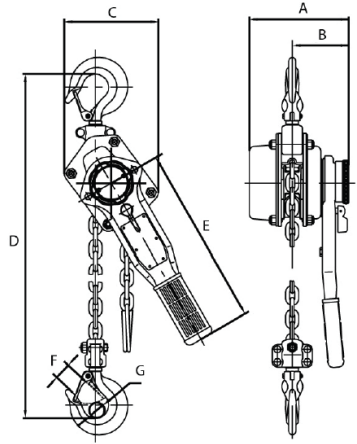

500KG / 800KG / 1.6T / 3.2T

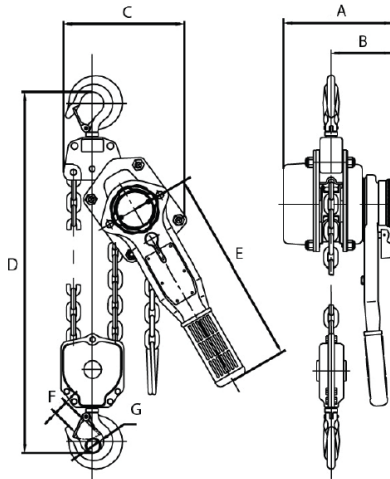

6.3T

Model	CLB202	CLB205	CLB208	CLB216	CLB232	CLB263	
Rated Capacity	250kg	500kg	800kg	1.6t	3.2t	6.3t	
Lifting Height (m)	1.5	1.5	1.5	1.5	1.5	1.5	
Test Load (kg)	375	750	1200	2400	4800	9450	
Effort to Lift Full Load (N)	115	248	285	315	360	370	
No. of Falls	1	1	1	1	1	2	
Load Chain Grade 80 (mm)	Φ4X12	Φ5X15	Φ5.6X17	Φ7.1X21	Φ10X28	Φ10X28	
Headroom (mm) H	235	310	340	400	520	640	
Length of Lever Handle (mm)	168	253	273	378	418	418	
Dimension (mm)	A	100	143	147	173	200	200
	B	70	85	87	99	112	112
	C	86	118	132	145	198	112
	D	18	20	25	30	36	230
	E	20	22	26	29	37	43
Net Weight incl. 1.5m (kg)	2.4	3.7	7	10	20	31	

PRE-START CHECKLIST

REGULAR INSPECTION OF YOUR CHALLENGER LEVER BLOCK WILL HAVE A TWOFOLD RESULT BY ENSURING THE UNIT IS SUITABLE FOR SAFE OPERATION AND WILL ASSIST WITH EXTENDING THE OPERATING LIFE OF THE UNIT. THE FOLLOWING INSPECTION SHOULD BE PERFORMED BOTH PRIOR TO, AND AFTER, EVERY USE:

- Ensure the lever block is correctly suspended from a suitable support which keeps the load chain off the ground whilst in storage
- Ensure the selected lever block is the correct capacity to perform the task required
- Handle your lever block with care and do not throw, drop or drag it along the ground
- Familiarise yourself with how the unit operates and understand its safety features
- Inspect the unit for any missing parts before and after every use
- Ensure the safety latches are working correctly and are aligned properly in the hook
- Check for free movement of the load chain by operating the lever handle
- Check the load hooks for ease of rotation
- Inspect the load chain before and after each use
- Check that the free-wheel knob rotates freely without jamming

ON SITE CHECKS

THERE ARE A NUMBER OF CHECKS RECOMMENDED WHEN USING THE CHALLENGER LEVER BLOCK ON SITE:

- Lever blocks can be used for both vertical and horizontal use
- Only competent persons should operate Challenger Lever Blocks and should have read the instruction manual and understood the operation of the device before use
- Follow all site safety rules where applicable in relation to the movement of suspended loads
- It is recommended that the lever block should not be exposed to elements such as: water, salt spray, steam or chemicals that may compromise the integrity of the device, without consulting your supplier
- Adopt safe slinging practices and follow all instructions carefully
- Ensure the load requirement of the job is within the rated capacity of the lever block
- Check that labelling and/or identification is correct and legible
- Ensure the Pre-Start Check List, as shown previously, has been conducted
- Make sure that no oil and/or grease make contact with the braking system of your lever block
- Check the environment and locality of the job to ensure personnel safety issues are acceptable for the intended use
- Check that the load connection point, where the lever block is to be attached, is capable of safely handling the intended load
- Where trolley suspension is required, ensure the trolley is correctly set for the beam width and that it moves freely along the beam
- Once the lever block is suspended, both hooks must be seated correctly ensuring the safety latches are engaged in the closed position
- Ensure the free end of the load chain is clear of any obstructions before and during operation
- Check that the bottom hook will reach its lowest point without fully extending the load chain
- The load should be free to move and the landing area cleared before starting any lifting operation
- When using a lever block with 2 falls (or more) of load chain, ensure that the lower hook block has not been inverted or twisted
- Start the lifting process carefully, and once the load is just clear, stop and check the integrity of the lever block and load assembly, including any rigging, before continuing the operation
- The operator should always have a clear view of the complete travel path of the load
- Ensure that the load will not be suspended from the lever block for any extended period of time without secondary restraint, it is advisable that suspended loads should not be left unattended
- Take care when placing heavy loads down into position that fingers and toes are kept clear

GENERAL PRECAUTIONS

- Always understand the operation of the Challenger Lever Block before putting it to use
- Always ensure you are working within the required guidelines of Workplace Health and Safety regulations relevant to the task being undertaken
- Never use a lever block to lift a load greater than its rated capacity
- Never use freewheeling lever blocks in tandem or on dual lift applications
- Always check for personnel within the work area and DO NOT use lever blocks to suspend loads over people
- Never use lever blocks for lifting or transporting people under any circumstances
- Never use the load chain of a lever block to wrap around the load
- Never operate a lever block with kinked or twisted load chain
- Always keep control of the load and do not allow it to swing excessively
- Avoid shock loading the lever block as it may seriously damage the operating system. If this occurs, remove the device from use
- Always ensure any slings or rigging gear being used are connected into the hooks, ensuring safety latches are engaged in the closed position
- Check for fixed obstructions which may catch the load during the lifting operation
- Lever blocks are designed for manual use only and must not be converted for power operation in any way
- Never modify your lever block from its designed configuration in any way
- Ensure only the original manufacturer's spare parts are used in the repair of any lever block
- Replace any load chain with original manufacturers specified chain only
- Galvanising or plating of load chain or load bearing parts is not recommended without the express approval of the supplier
- Never replace a worn load chain without having the lever block fully inspected by a trained staff member.

OPERATING INSTRUCTIONS

The Challenger Lever Block has been designed for manual operation only. It utilises a reciprocal operating lever handle to drive a series of gears via a unique braking system to raise (or tension) and lower (or release) a load both vertically and horizontally.

- Place lever block into the required position to perform the lifting (or tensioning) operation, ensuring the top hook is positioned correctly with the safety latch engaged as required
- To raise the bottom hook without any load applied, use the lever block in the Free Wheel mode by placing the select handle in the centre position
- While the unit is in Free Wheel mode, the load chain can be pulled through the device by hand in either direction to position the hook in the desired location
- Once the load has been connected to the lower hook, ensure the safety latch is engaged correctly
- Move the select lever to the raise position
- Operating the lever handle using a circular motion or a reciprocating (back and forth) motion will begin lifting or tensioning the load
- Start the lifting or tensioning process carefully, and once the load is taken up, stop and check the integrity of the lever block, the load assembly, including any rigging gear, and that the load path is clear before continuing the lifting or tensioning
- Continually using a reciprocating movement will raise or tension the load while the select lever is in the raise position
- If the handle movement is stopped at anytime during the raising (tensioning) of the load, the lever block will continue to hold the load automatically
- To lower the bottom hook, first move the select lever into the lower position
- Take care before commencing lowering (or retracting) of the load, to ensure that the load path is clear and unobstructed by obstacles or by persons near the work area
- Operating the lever handle using a circular motion or a reciprocating (back and forth) motion will lower the load
- When raising or lowering a load, the desired operation is a smooth backward and forward arm movement. Excessive speed is not recommended
- Once load is in desired position, continuing the reciprocating movement will release the tension of the load chain

- After ensuring the load has been placed safely and securely, release the safety latch of the bottom hook and remove it from the load
- The unit can then be used in the Free Wheel mode to quickly move the lower hook to a position where the lever block and chain can be safely removed from the job site
- After removing the lever block from use, a visual inspection should be performed to cover the points listed in the Pre-Start Check List previously described
- Ensure the unit is stored correctly in a suitable secure location where unauthorised persons do not have access

SPARE PARTS FOR 250KG MODEL

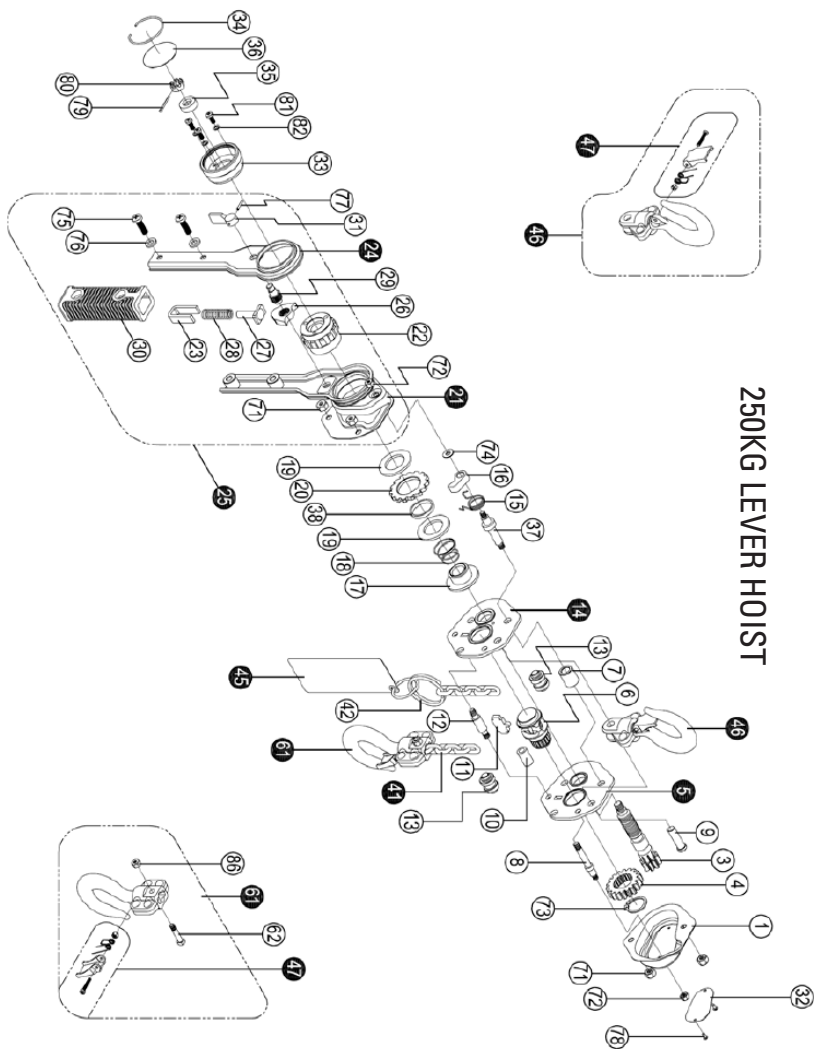

SPARE PARTS FOR 250KG MODEL

CODE	NO	DESCRIPTION
710500	1	Gear cover
710501	3	Drive shaft
710502	4	Splined gear
710503	5	Right side plate assy
710504	6	Load chain sprocket
710505	7	Bush A
710506	8	Stay bolt C
710507	9	Top hook shaft
710508	10	Bush B
710509	11	Chain stripper
710510	12	Stay bolt A
710511	13	Guide roller
710512	14	Left side plate assy
710513	15	Pawl spring
710514	16	Pawl
710515	17	Brake seat
710516	18	Free spring
710517	19	Friction plate
710518	20	Ratchet wheel
710519	21	Ratchet wheel cover assy
710520	22	Changeover ratchet wheel
710521	23	Spring seat
710522	24	Right lever handle assy

CODE	NO	DESCRIPTION
710523	25	Handle assy
710524	26	Changeover pawl
710525	27	Spring shaft
710526	28	Changeover spring
710527	29	Selector plate shaft
710528	30	Handle rubber grip
710529	31	Selector plate
710530	32	Nameplate
710531	33	Hand wheel
710532	34	Steel wire retainer
710533	35	Step washer
710534	36	Hand wheel nameplate
710535	37	Stay bolt B
710536	38	Bushing
CHN250	41	Load Chain mm 4 x 12
710537	42	Chain ring
710538	45	Warning plate assy
710539	46	Top hook assy
710540	47	Safety latch assy
710541	61	Bottom hook assy
710542	62	Bottom hook pin
710543	73	Circlip 20
710544	74	Pawl washer
710547	77	Spring pin 2x12
710549	79	Split pin 2x16

SPARE PARTS FOR 500KG - 6.3 TONNE MODELS

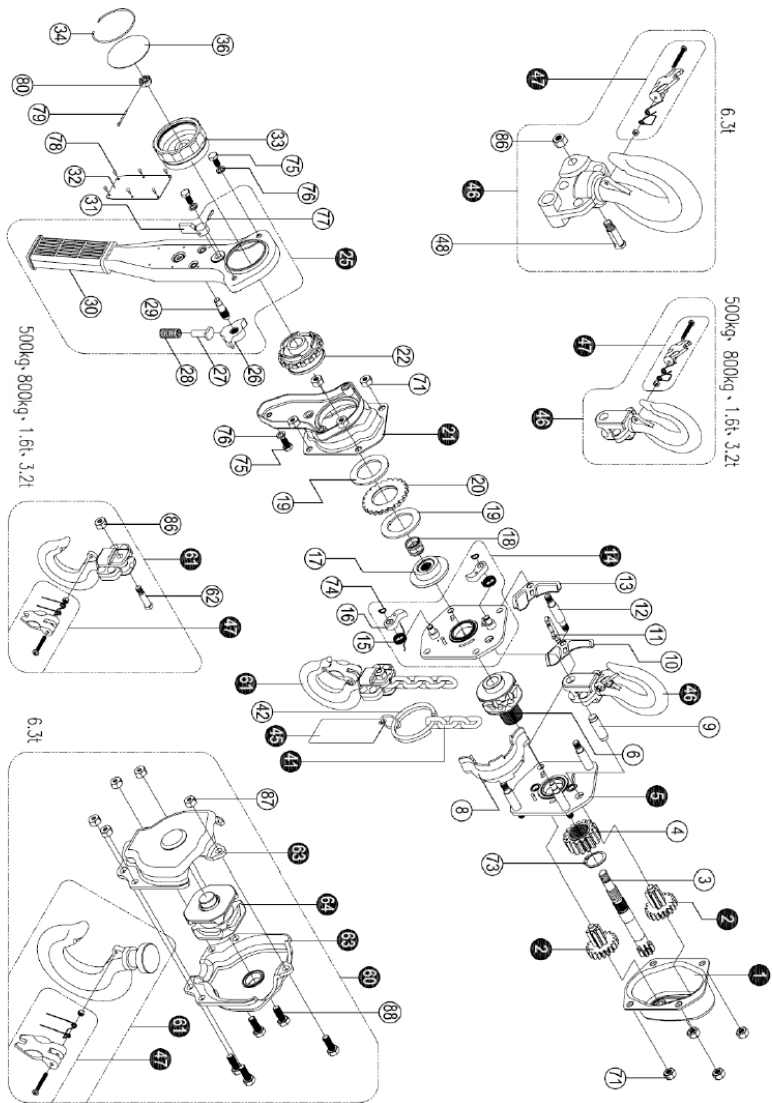

SPARE PARTS FOR 500KG MODEL

CODE	NO	DESCRIPTION
710560	1	Gear cover 0.5T
710561	2	Disc gear assy
710562	3	Drive shaft
710563	4	Splined gear
710564	5	Right side plate assy
710565	6	Load chain sprocket
710566	8	Chain guide
710567	9	Top hook shaft
710568	10	Chain leader A
710569	11	Chain stripper
710570	12	Stay bolt B
710571	13	Chain leader B
710572	14	Left side plate assy
710573	15	Pawl spring
710574	16	Pawl
710575	17	Brake seat
710576	18	Free spring
710577	19	Friction plate
710578	20	Ratchet wheel
710579	21	Ratchet wheel cover assy
710580	22	Changeover ratchet wheel

CODE	NO	DESCRIPTION
710581	25	Handle assy
710582	26	Changeover pawl
710583	27	Spring pin
710584	28	Changeover spring
710585	29	Selector shaft
710586	30	Handle rubber grip
710587	32	Nameplate
710588	33	Hand wheel
710589	35	Step washer
710590	36	Hand wheel nameplate
CHN100	41	Load Chain mm 5 x 15
710591	42	Chain ring
710592	45	Warning plate assy
710593	46	Top hook assy
710594	47	Safety latch assy
710595	61	Bottom hook assy
710596	62	Bottom hook pin
710597	71	Metal lock nut M8
710598	73	Circlip 26
710599	74	Circlip 8
710600	76	Light spring washer 6
710601	77	Spring pin 3x18
710602	78	Nameplate rivet 2.5x6

SPARE PARTS FOR 800KG MODEL

CODE	NO	DESCRIPTION
710610	1	Gear cover 0.8T
710611	2	Disc gear assy
710657	3	Drive shaft
710613	4	Splined gear
710614	5	Right side plate assy
710615	6	Load chain sprocket
710616	8	Chain guide
710617	9	Top hook shaft
710618	10	Chain leader A
710619	11	Chain stripper
710620	12	Stay bolt B
710621	13	Chain leader B
710622	14	Left side plate assy
710623	15	Pawl spring
710624	16	Pawl
710625	17	Brake seat
710626	18	Free spring
710627	19	Friction plate
710628	20	Ratchet wheel
710629	21	Ratchet wheel cover assy
710658	22	Changeover ratchet wheel
710691	23	Brake torsion spring

CODE	NO	DESCRIPTION
710633	25	Handle assy
710634	26	Changeover pawl
710635	27	Spring pin
710636	28	Changeover spring
710637	29	Selector shaft
710638	30	Handle rubber grip
710639	32	Nameplate
710659	33	Hand wheel
710642	35	Step washer
710643	36	Hand wheel nameplate
CHN400	41	Load Chain mm 5.6 x 17
710644	42	Chain ring
710645	45	Warning plate assy
710646	46	Top hook assy
710647	47	Safety latch assy
710648	61	Bottom hook assy
710649	62	Bottom hook pin
710650	71	Metal lock nut M8
710651	73	Circlip 26
710652	74	Circlip 8
710653	76	Light spring washer 6
710654	77	Spring pin 3x18
710655	78	Nameplate rivet 2.5x6
710656	79	Split pin 2.5x25

SPARE PARTS FOR 1.6 TONNE MODEL

CODE	NO	DESCRIPTION
710670	1	Gear cover
710671	2	Disc gear assy
710718	3	Drive shaft
710673	4	Splined gear
710674	5	Right side plate assy
710675	6	Load chain sprocket
710676	8	Chain guide
710677	9	Top hook shaft
710678	10	Chain leader A
710679	11	Chain stripper
710680	12	Stay bolt B
710681	13	Chain leader B
710682	14	Left side plate assy
710683	15	Pawl spring
710684	16	Pawl
710685	17	Brake seat
710686	18	Free spring
710687	19	Friction plate
710688	20	Ratchet wheel
710689	21	Ratchet wheel cover assy
710719	22	Changeover ratchet wheel
710692	23	Adjusting block

CODE	NO	DESCRIPTION
710693	25	Handle assy
710694	26	Changeover pawl
710695	27	Spring pin
710696	28	Changeover spring
710697	29	Selector shaft
710698	30	Handle rubber grip
710699	31	Selector plate
710700	32	Nameplate
710720	33	Hand wheel PSP
710703	35	Step washer
710704	36	Hand wheel nameplate
CHN410	41	Load Chain mm 7.1 x 21
710705	42	Chain ring
710706	45	Warning plate assy
710707	46	Top hook assy
710708	47	Safety latch assy
710709	61	Bottom hook assy
710710	62	Bottom hook pin
710711	71	Metal lock nut M10
710712	73	Circlip 30
710713	74	Circlip 9
710714	76	Light spring washer 8
710715	77	Spring pin 3x18
710716	78	Nameplate rivet 2.5x6
710717	79	Split pin 2.5x25

SPARE PARTS FOR 3.2 TONNE MODEL

CODE	NO	DESCRIPTION
710730	1	Gear cover
710731	2	Disc gear assy
710778	3	Drive shaft
710733	4	Splined gear
710734	5	Right side plate assy
710735	6	Load chain sprocket
710736	8	Chain guide
710737	9	Top hook shaft
710738	10	Chain leader A
710739	11	Chain stripper
710740	12	Stay bolt B
710741	13	Chain leader B
710742	14	Left side plate assy
710743	15	Pawl spring
710744	16	Pawl
710745	17	Brake seat
710746	18	Free spring
710747	19	Friction plate
710748	20	Ratchet wheel
710749	21	Ratchet wheel cover assy
710779	22	Changeover ratchet wheel
710752	23	Adjusting block

CODE	NO	DESCRIPTION
710780	33	Hand wheel
710753	25	Handle assy
710754	26	Changeover pawl
710755	27	Spring pin
710756	28	Changeover spring
710757	29	Selector shaft
710758	30	Handle rubber grip
710759	31	Selector
710760	32	Nameplate
710764	36	Hand wheel nameplate
CHN440	41	Load Chain mm 10 x 28
710765	42	Chain ring
710766	45	Warning plate assy
710767	46	Top hook assy
710768	47	Safety latch assy
710769	61	Bottom hook assy
710770	62	Bottom hook pin
710771	71	Metal lock nut M12
710772	73	Circlip 42
710773	74	Circlip 9
710774	76	Light spring washer 8
710775	77	Spring pin 3x18
710776	78	Nameplate rivet 2.5x6

SPARE PARTS FOR 6.3 TONNE MODEL

CODE	NO	DESCRIPTION
710790	1	Gear cover
710791	2	Disc gear assy
710778	3	Drive shaft
710793	4	Splined gear
710794	5	Right side plate assy
710795	6	Load chain sprocket
710796	8	Chain guide
710797	9	Top hook shaft
710798	10	Chain leader A
710799	11	Chain stripper
710800	12	Stay bolt B
710801	13	Chain leader B
710802	14	Left side plate assy
710803	15	Pawl spring
710804	16	Pawl
710805	17	Brake seat
710806	18	Free spring
710807	19	Friction plate
710808	20	Ratchet wheel
710809	21	Ratchet wheel cover assy
710779	22	Changeover ratchet wheel

CODE	NO	DESCRIPTION
710752	23	Adjusting block
710813	25	Handle assy
710814	26	Changeover pawl
710815	27	Spring pin
710816	28	Changeover spring
710817	29	Selector shaft
710818	30	Handle rubber grip
710819	31	Selector
710820	32	Nameplate
710780	33	Hand wheel
710824	36	Hand wheel nameplate
CHN440	41	Load Chain mm 10 x 28
710825	42	Chain ring
710826	45	Warning plate assy
710827	46	Top hook assy
710828	47	Safety latch assy
710829	48	Bottom hook pin
710830	61	Bottom hook assy
710831	63	Bottom hook connector assy
710832	64	Idler sheave
710833	71	Metal lock nut M12
710834	73	Circlip 42
710835	74	Circlip 9
710836	76	Light spring washer 8
710837	77	Spring pin 3x18
710838	78	Nameplate rivet 2.5x6
710839	79	Split pin 2.5x25

MAINTENANCE

It is the responsibility of the owner/operator to ensure lever blocks are maintained and tested in accordance with AS1418.2. Regular maintenance is vital in upkeeping the efficiency of the lever blocks and also maximises their lifetime.

- Only authorised personnel should undertake to do repairs and testing on lifting equipment
- Keep load chains lubricated
- Always check the operation of the brake before starting to move a load
- Brakes must be kept free of oil and grease
- Safety latches should be free of defect and move freely with proper fitment to the hook

If any of the following defects are evident, the lever block should be referred to a qualified technician or service centre for a more thorough examination, servicing and testing:

- Evidence of possible wear to hooks and fittings
- Damaged or distorted chain end anchor
- Chain wear including bends, notches, elongations, corrosion, not hanging freely or twisted
- Load slipping, jamming or will not lift
- Damaged covers
- Illegible markings
- Bent operating handles or other obvious damage

SPARE PARTS

General inspections are visual and should be carried out by the operator or any designated persons responsible for the equipment

Service Inspections should only be performed by authorised personnel qualified to undertake Service, Repairs and Testing

ITEM	CHECK	GENERAL INSPECTIONS	SERVICE INSPECTIONS
Brake Assembly	Slipping under load or difficulty of release	X	X
Brake Disc	Glazing or score marks. Oil or contamination		X
Pawl: Ratchet	Worn or damaged		X
Pawl: Spring	Engagement, corrosion, stretching		X
Top and Bottom Hooks	Corrosion, deformation	X	X
Hook Retaining Components Nuts, Bolts, Pins	Not tight or secure	X	X
Hook Latches	Damaged, do not engage	X	X
Suspension Members, Sheaves, Hand Wheels, Chain Guides, Attachments, Suspension Pins and Bolts	Wear, cracks, elongation	X	X
Gears	Distortion, worn or broken teeth, lack of lubrication		X
Load Chain	Grade, wear, elongation, twisted or damaged, lack of lubrication	X	X
Handle, Assembly	Bent, damaged, select lever functional	X	X
Covers, Labelling	Removed, damaged or illegible	X	X



INSPECTION LOG

INITIAL SERVICE DATE:

SERIAL NO:

DATE	NOTES	AUTH SIGNATURE

Imported exclusively by Pacific Hoists Pty. Ltd. & Pacific Hoists Ltd.
For further information in relation to this product,
please contact the branch where the product was purchased.

HEAD OFFICE

24 Foundry Road, Seven Hills NSW 2147 Australia
11 Druces Road Wiri, Auckland 2104 New Zealand
National Sales & Service P: 02 8825 6900
www.pacifichoists.com.au



Thank you for choosing the Challenger brand. Not only are you choosing a quality and reliable brand but you are also helping to support cancer charities in Australia & New Zealand.