

Description

Provides a temporary barrier to clearly identify hazardous or dangerous areas. Supplied complete with 16m of durable red/white tape with hook & eyelet. Automatic spring rewind mechanism and swivelling steel wall bracket.

A must for addressing workplace and employee safety.



Ratcheted stop device - ON-OFF



The manufacturer, indicated by this label, declares under his sole responsibility that the product specified here conforms to the following regulations: Air reel: 2006/42/CE Electric reel: 2006/42/CE - 2014/35/CE - 2011/65/UE (RoHs)





OWNER'S TECHNICAL MANUAL

BRP5216

Safety Barrier Reel

CAUTION!

Before using this product, carefully read the general safety rules and instructions listed below.
Before starting work, make sure that you know how to stop the Safety Barrier Reel Tape in the event of emergency.
Any other than the intended operation could damage the product or cause serious injury.
Keep these instructions in a safe place and on hand so that they can be read when required.
Do not remove, modify, or inhibit safety devices put in place by the manufacturer.

GENERAL SAFETY RULES

- 1) This product must not be used by children or unskilled persons.
- 2) Always check the good working order of the product which, if not adequate, could endanger the user.
- 3) Never remove any of the Safety Barrier Reel's components.
- 4) Do not insert objects or place fingers on the Barrier Reel aperture during Tape rewinding.
- 5) Do not leave the Safety Barrier Reel unattended during rewinding.

INSTALLATION

Fasten the Safety Barrier Reel to the wall using appropriate wall plugs. Check that the Tape returns in a straight-line with respect to the casing and make sure that is not dragged along the sides of the opening when entering.
The Safety Barrier Reel is supplied with a ratcheted stop device which clamps the Tape in the required position.
To stop the Tape from being clamped so that it can unwind freely, see drawing on page 1.

MAINTENANCE

Periodically:

- Check that the spring is working and that the Tape is coiled properly.
- Check the Safety Barrier Reel & Tape for damage. If damaged do not use, have it repaired by an authorised service person.
- Check that the gripper teeth are working properly.
- Check the anchoring of the required Safety Barrier Reel on the wall, ceiling or floor.

GUARANTEE

24 MONTHS from the date of purchase. Alemlube commits to carrying out, free of charge, the replacement of faulty parts or defects in manufacture.
Problems caused by incorrect use, tampering or negligence are not covered by the guarantee.
Shipping charges shall be incurred by the buyer.

NSW
TEL: (02) 9677 1555
FAX: (02) 9675 1155

QLD/PNG
TEL: (07) 3204 9166
FAX: (07) 3204 1224

VIC/TAS
TEL: (03) 8787 8288
FAX: (03) 8787 8266

WA
TEL: (08) 9302 4199
FAX: (08) 9303 2095

SA/NT
TEL: (08) 8241 7111
FAX: (08) 8241 7011

NZ
TEL: (64) 9 447 1007
FAX: (64) 9 447 1008

Parts And Drawing Breakdown For The BRP5216

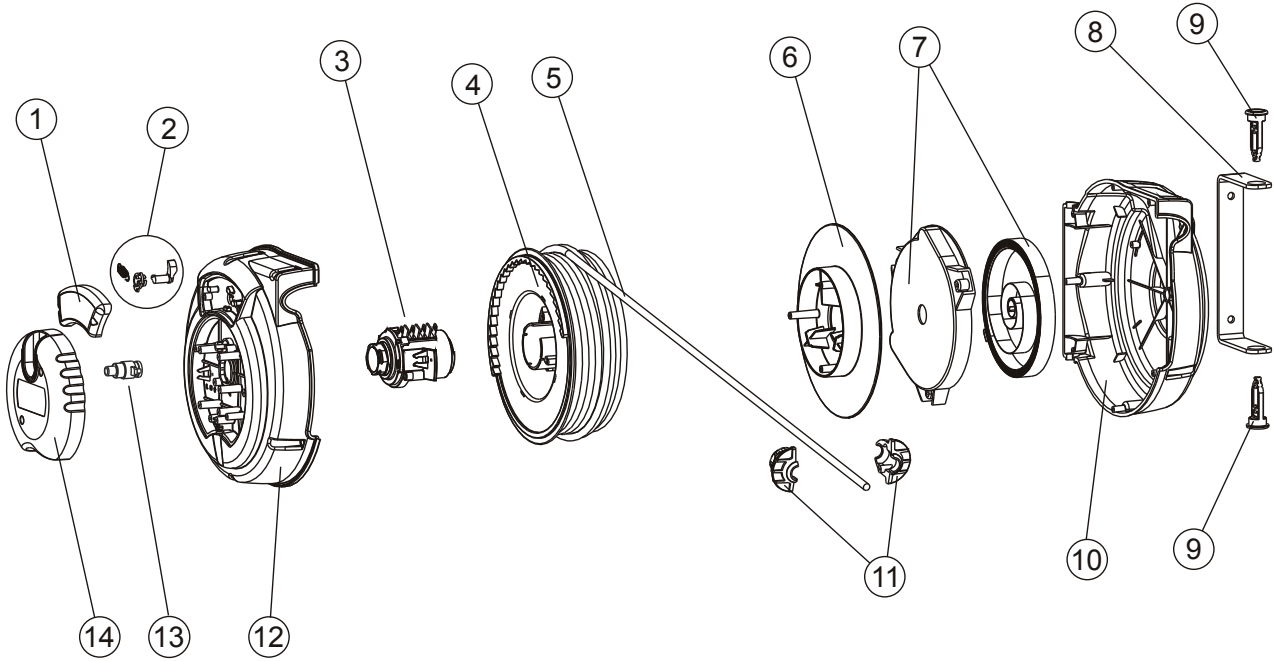

Safety Barrier Reel

Model BRP5216

SAFETY BARRIER REEL
324206
704904
704151
322124
711010
322127
705035
620125
324230
328102 (Red)
323346
328010 (Red)
/
324286

NSW
TEL: (02) 9677 1555
FAX: (02) 9675 1155

QLD/PNG
TEL: (07) 3204 9166
FAX: (07) 3204 1224

VIC/TAS
TEL: (03) 8787 8288
FAX: (03) 8787 8266

WA
TEL: (08) 9302 4199
FAX: (08) 9303 2095

SA/NT
TEL: (08) 8241 7111
FAX: (08) 8241 7011

NZ
TEL: (64) 9 447 1007
FAX: (64) 9 447 1008