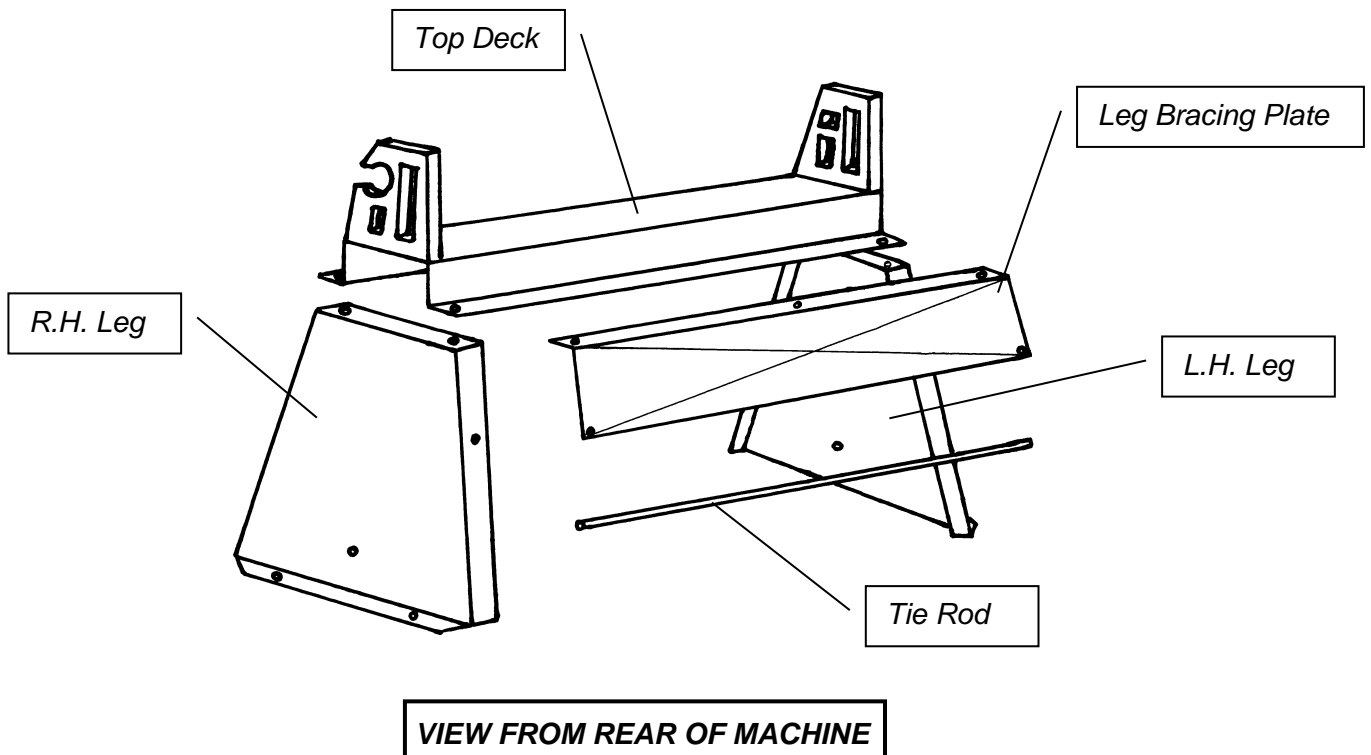

Assembly Instructions**CONTENTS:**

- 1) Rolls assembled on Top Deck
1 x Leg Bracing Plate
1 x Main Handle for machine
1 x Tie Rod (fitted with bolt & washer each end)

 - 2) Package containing the following:-
 - 1 x Right Hand Leg
 - 1 x Left Hand Leg
 - 1 x Fasteners Pack
-
- 1) Unpack all packages and ensure you have all components as per the above list.
 - 2) Assemble Tie Rod onto Legs with 2 x M10 Bolts & Flat washers
 - 3) Remove Curving Rolls Assembly from the pallet and place on top of the legs. Screw onto legs with 2 x M10 bolts & Flat Washers on the front of the Curving Rolls only.

Note: The stand incorporates a Leg Bracing Plate for strength. This is fitted on the rear of the machine. (Front & rear positions are determined by having the gears on your right when facing the machine) See diagram.

- 4) The Leg Bracing Plate is then fitted on the rear of the machine with M10 Bolts & Nuts with a washer under each
- 5) Ensure all Bolts & Nuts are securely tightened
- 6) The bottom of the leg has a folded return with 10mm dia clearance holes which are suitable for securing the machine to the floor with a 'Dynabolt' or similar.
- 7) To fit the Main Handle to the machine, remove the "Roll-Pin" from the bottom roll. Fit the handle until the hole is aligned with the hole in the shaft & re-insert the "Roll-Pin".

Your 'Bramley' Australian Made Sheetmetal Curving Rolls are now ready for use.



BRAMLEY



Manufactured by:

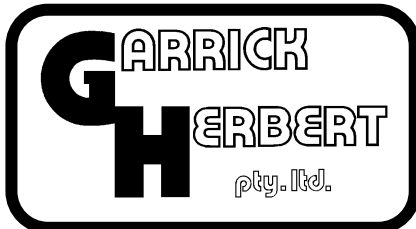

460-462 The Boulevard
(P.O.) Box 3118 Kirrawee, NSW 2223
AUSTRALIA

Ph: +61-2-9545 6633
Fax: +61-2-9545 4222

Email: sales@garrickherbert.com.au

In the interests of continual product improvement, the manufacturer reserves the right to alter specifications