

## Operating Instructions & Parts List

# Bramley Hydraulic Thin Wall Tube Bender

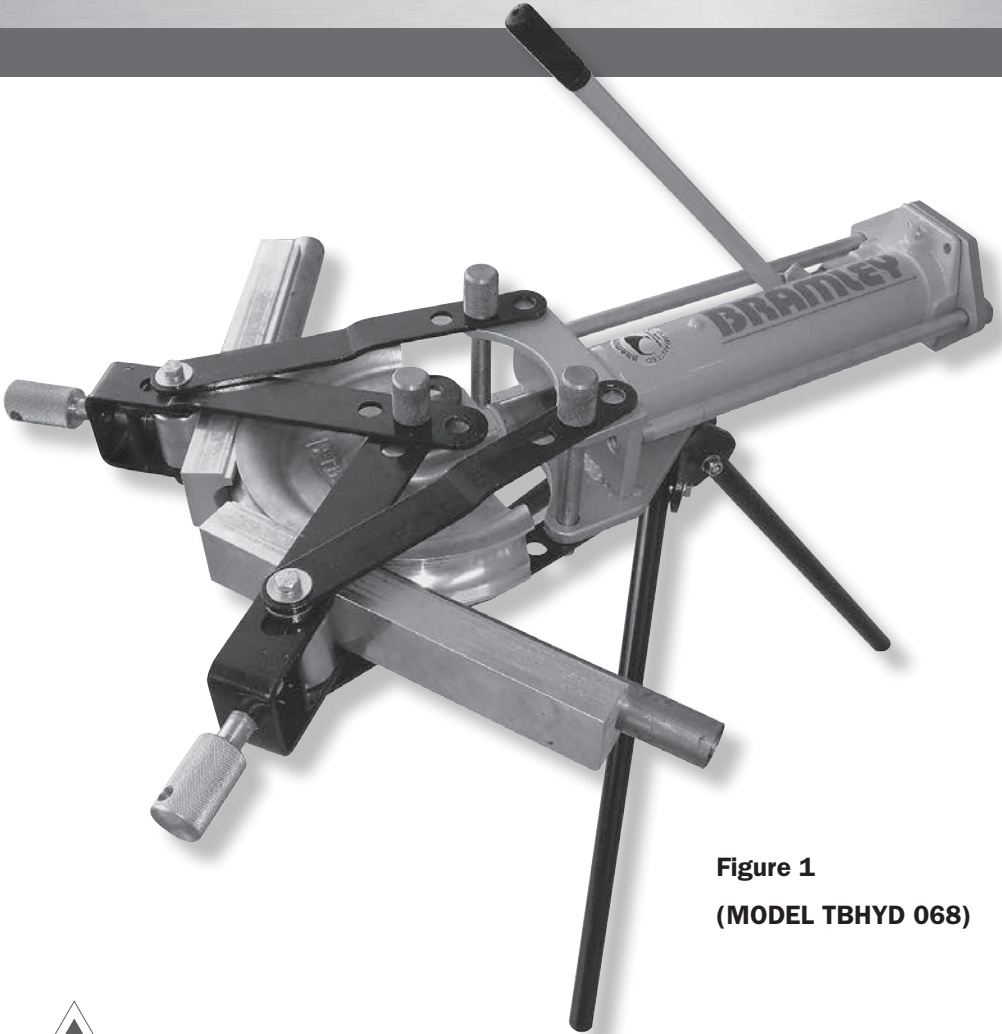

**Figure 1**

**(MODEL TBHYD 068)**



# BRAMLEY

# Bramley Hydraulic Thin Wall Tube Bender (Model TBHYD)

**Thank you for purchasing the Bramley Hydraulic Thin Wall Tube Bender. This portable Machine is designed for general-purpose use.**

**Formers for the machine illustrated that are available are: 1", 1-1/8" 1-1/4", 1-3/8", 1-1/2", 1-5/8", 1-3/4", 1-7/8" and 2" Formers. (See Figure 3).**

**This Machine is designed to bend mild steel tube of 1" to 2" capacity (and up to 2mm wall thickness) to a maximum angle of 180 degrees.**

## Operation and Assembly

1. Mount the hydraulic power pack on the Tripod leg base.
  2. Choose the desired Former for bending and place it on the end of the Hydraulic Ram.
  3. NOTE: The Formers are designed for use on standard 1.6mm and 2mm mild steel tube.
  4. Mount the slipper follower arm assemblies on the front of the tube bender utilizing the three pins supplied (as in figure 1 - on front cover). *Note:*
    - The smaller formers (1", 1.1/8" & 1.1/4") require the location pins to be inserted in the shortest hole pitching.
    - The mid-range formers (being 1-3/8", 1.1/2", 1.5/8") require the location pins to be inserted in the middle hole pitching.
    - The large formers (being 1.3/4", 1.7/8" and 2") require the location pins to be inserted in the largest hole pitching.
  5. Ensure that the slipper arm assemblies are at the front most position – closest position together.
  6. Insert the tubing to be bent into the machine between the slipper rollers and the tube former (as in figure 1).
  7. Then insert the corresponding slippers from each side such that they butt up to each other where the centre of the bend will be – middle of former (as in figure 1).
  8. Screw up the adjusting screws so that the tubing is fitting snugly between the former and the slippers (as in figure 1).
  9. Screw the pressure release screw shut on the hydraulic ram and proceed pumping the hydraulic unit until the desired bend angle has been achieved – maximum 180 degrees.
  10. When the Tube has been bent to the desired angle, you then return the Hydraulic ram to the retracted position by releasing the pressure release tap at the bottom of the Hydraulic ram.
  11. Then holding the slipper adjusting screws push them together back to the original straight forward position.
  12. This in turn retracts the ram and former back to its original position.
  13. Pull the three link arm pins out of the slipper follower arm assemblies & the former.
  14. Gently remove the former from the inside of the bend.
  15. Re-assemble unit and repeat the above steps to produce subsequent bends.
- Hydraulic Oil should be checked periodically by removing the rubber cap over the oil filler hole. Stand the unit in an upright manner and fill Hydraulic Reservoir with 32 Grade Hydraulic Oil.

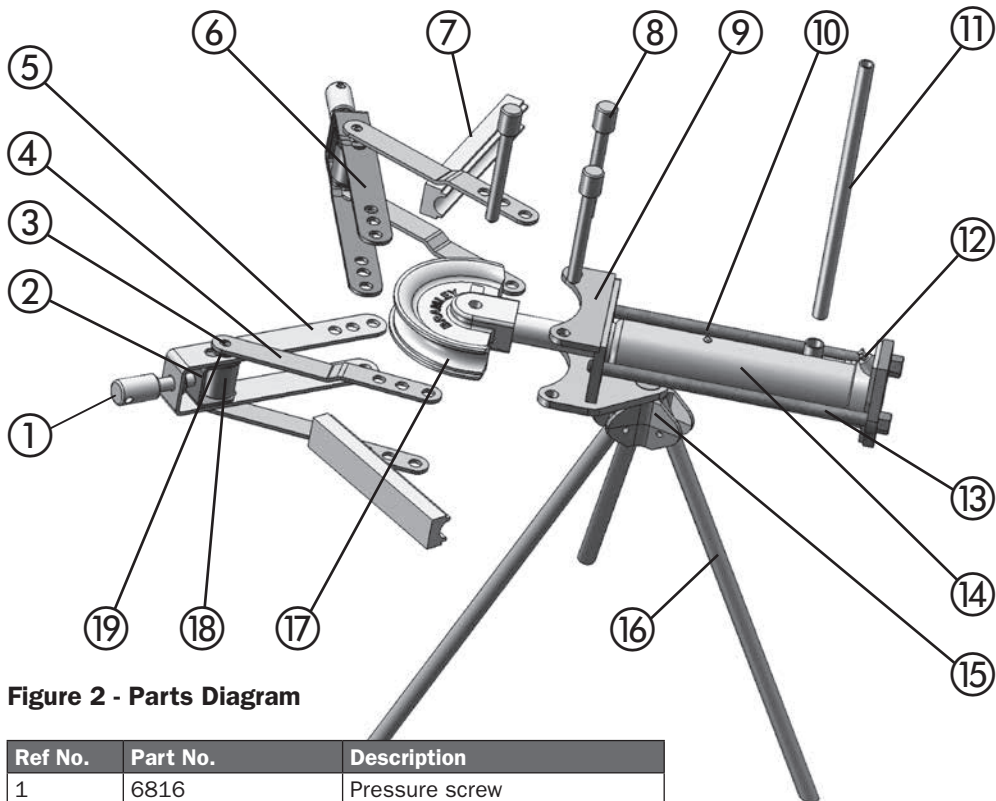
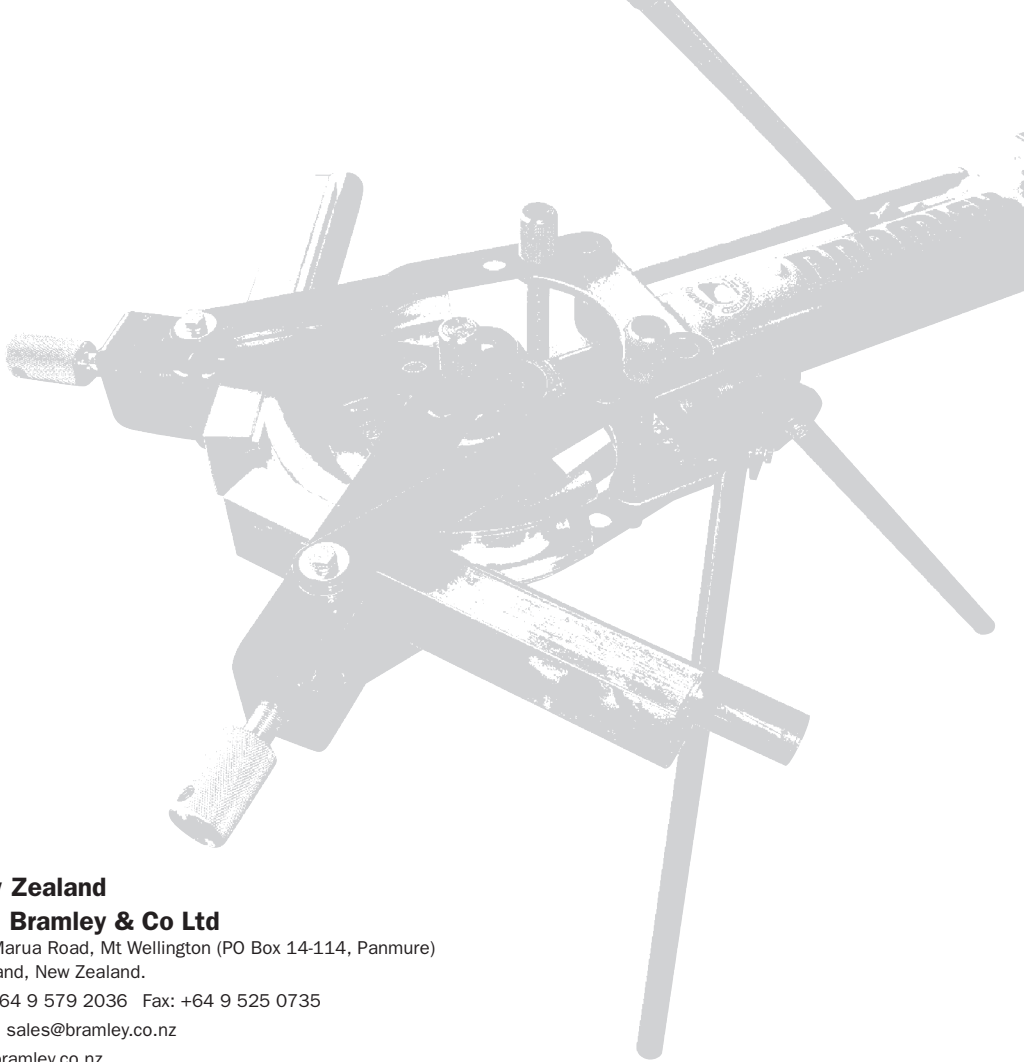

**Figure 2 - Parts Diagram**

Ref No.	Part No.	Description
1	6816	Pressure screw
2	6811	Slipper Roller Clevis
3	6814	Slipper Roller Pin
4	6810	Link Arm (x2)
5	6808	Slipper Roller Support straight
6	6809	Slipper Roller Support Bent
7		Slipper
8	6817	Link Arm Pins
9	6805	Top Plate
10		Oil Filler Bung
11		Handle
12		Pressure release screw
13	6804	Tie Rod
14		Hydraulic Ram
15	6818	Tripod Head
16	6819	Leg (x3)
17		Former
18	6812	Slipper Roller
19	6813	Slipper Roller Spacer

Tube Size	Centreline Radius of Bend
1" (25.4mm)	115mm
1.1/8" (28.6mm)	115mm
1.1/4" (31.8mm)	115mm
1.3/8" (35mm)	140mm
1.1/2" (38mm)	140mm
1.5/8" (41.3mm)	140mm
1.3/4" (44.5mm)	165mm
1.7/8" (47.6mm)	165mm
2" (51mm)	165mm

**Figure 3 - Formers Size Range**



## **New Zealand**

### **R.R. Bramley & Co Ltd**

184 Marua Road, Mt Wellington (PO Box 14-114, Panmure)  
Auckland, New Zealand.

Ph: + 64 9 579 2036 Fax: +64 9 525 0735

Email: [sales@bramley.co.nz](mailto:sales@bramley.co.nz)

[www.bramley.co.nz](http://www.bramley.co.nz)

## **Australia**

### **Garrick Herbert Pty Lyd**

460-462 The Boulevarde (PO Box 3118)  
Kirrawee, NSW 2232, Australia

Ph: + 61 2 9545 6633 Fax: +61 2 9545 4222

Email: [sales@garrickherbert.com.au](mailto:sales@garrickherbert.com.au)

[www.garrickherbert.com.au](http://www.garrickherbert.com.au)

## **USA & Canada**

### **Garrick USA LLC**

5455 West 6th Street (PO Box 874)  
Winona, MN 55987, USA

Ph: +1 507 474 9660

Email: [sales@garrickusa.com](mailto:sales@garrickusa.com)

[www.garrickusa.com](http://www.garrickusa.com)

# **BRAMLEY**

**Precision and Mechanical Engineers  
Machine Tool Manufacturers**