



KCP Gear Coupling follows the international standards of AGMA and JIS, which easily allows to replace with major industrial products. Our Gear coupling compensate angular misalignment, parallel misalignment and end float. The fully crowned hub teeth provide minimum loading stress, and ensure longer life.

1. Characteristic

1. High torque, small size, long life and very little loss of transmitting power.
2. The concave-convex flange design allows easy assembly and the high quality gasket prevent leakage of lubricant.
3. Gear Coupling permits parallel, angular misalignments and end floating by crown gear teeth.

■ Parallel Misalignment

The driving and driven shafts are not parallel to each other, but not on the same straight line.

■ Angular Misalignment

The driving and driven shafts installed with a limited angle.

■ End Floating

The driving and driven shafts slide slightly along with the gear teeth.

■ Composite Misalignment

Most of cases, above 3 misalignments appear with mixed in general use.

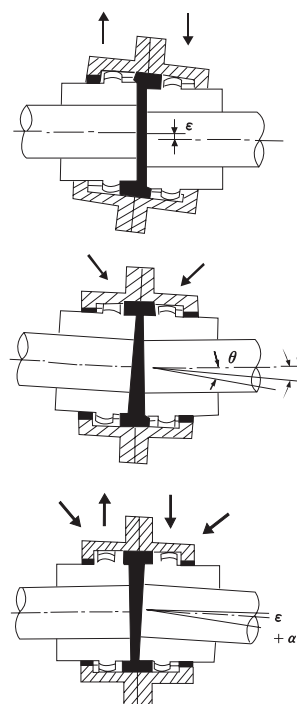

Allowable Misalignment

Size S	10G	15G	20G	25G	30G	35G	40G	45G	50G	55G	60G	70G	80G	90G	100G	110G	120G
ϵ (mm)	1.2	1.3	1.7	2.1	2.4	2.9	3.2	3.6	4.1	4.5	5.0	5.9	6.7	7.4	8.2	12.7	12.7
θ° (α)	3(1.5)	3(1.5)	3(1.5)	3(1.5)	3(1.5)	3(1.5)	3(1.5)	3(1.5)	3(1.5)	3(1.5)	3(1.5)	2(1)	2(1)	2(1)	2(1)	2(1)	2(1)

■ Data subject to double engagement couplings.

5. The coupling made of S45C has a good endurance to high speed and peak load.

Consult us for special materials, if required.

6. Customer's requirements of special design can be acceptable.

2. Structure

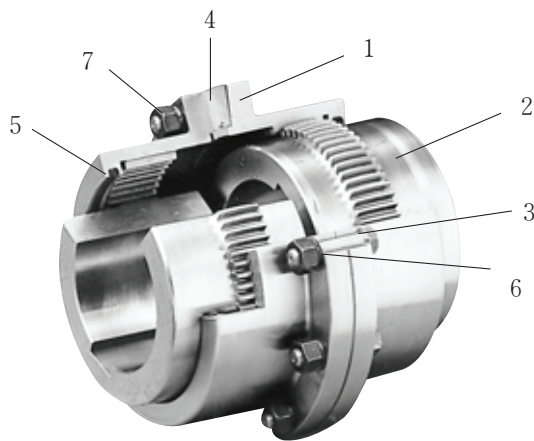

1. Internal Gear(Flanged Sleeve)
2. Crown Gear(Crown Gear Hub)
3. Reamer Bolt or AGMA Bolt
4. Gasket
5. O-ring
6. Spring Washer
7. Hex. Bolt & Nut.

■ The crowned hub teeth provide larger contact area and decrease the stress.

3. Application

1. Heavy load, but compact design coupling.
2. High speed up to 5,000rpm(Depending on size, refer to the data)
3. Low speed, but high starting torque.
4. End float application.
5. Spacer required, due to longer distance between shaft ends.
6. Low load and light weight application is not recommendable.

4. Standard Material

INTERNAL GEAR	CROWN GEAR	FLANGE	Bolt	O-Ring
SM 45C-N			SM 45C-H	NBR

- Special material and/or special treatment is required under the unusual application environments, such as high speed, high or low temperature, chemical corrosiveness, maximum load stress.
- Under the heavy load, high speed and corrosive environment, special materials shall be required.

5. Selection method of size

1. Selection

① Using the following formula, obtain Design Torque required.

$$T = 97,400 \frac{\text{kw}}{\text{N}} \times \text{S.F} \quad \text{또는} \quad T = 71,620 \frac{\text{HP}}{\text{N}} \times \text{S.F}$$

- T = Design torque(kg · cm)
- kw = Power(kw)
- HP = Power(HP)
- N = Working revolution (rpm)
- S · F = Recommended Service Factor

② Select the size with the same or greater value at the Basic Torque column, Refer to the maximum speed allowed to the size selected size, and then compare the shaft diameters of the application with the max. bore dia of the selected size. If the coupling bore is not suitable, select the next larger coupling size.

2. Special requirements.

- ① At the application of the Sliding Gear Coupling (type KGH) that endfloat movement occurs more than 5 times per hour, add 0.5 to the listed value of service factor
- ② At the applications such as continuous reverse revolutions, intermit operation, often peak load and high inertia required system, multiply 1.5 to the Design Torque calculated.
- ③ In the type of KGES-R and KGFS-O, the thickness and length of intermediate shaft must be determined according to our company's material specifications, consult with our Engineer.
- ④ Selecting the size of types KGDBW and KGSBW : apply brake power, if exceeds the prime mover power.

3. Example

Select Gear Coupling to connect 450HP 1,170rpm electric motor with reducer.
 Motor shaft diameter is 80 ϕ mm, Reducer shaft diameter is 90 ϕ mm, Max. parallel alignment is 1.5mm

- ① Select type KGDE for higher valued application of parallel misalignment.
- ② Service factor is 2.0
- ③ Use the normal formula

$$\text{HP}/100\text{rpm} = \frac{450 \times 100 \times 2.0}{1.170} = 76.9$$

Size KGDE25 is selected with rating of 90 HP per 100rpm. To apply larger shaft dia 90 ϕ mm, finally KGDE 30 is selected.

6. Designation

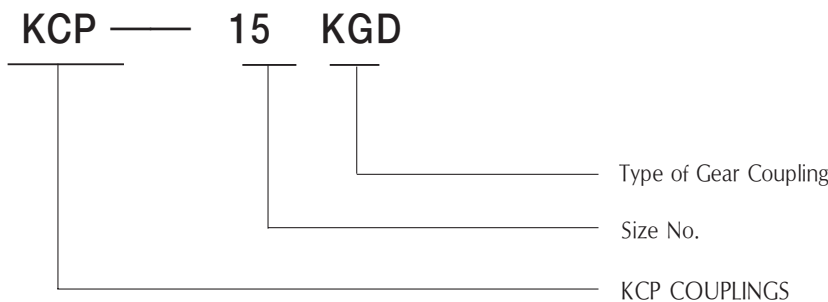

- KGD : Double Engagement Coupling
- KGDL : Double Engagement Large Coupling
- KGS : Single Engagement Coupling
- KGSL : Single Engagement Large Coupling
- KGDS : Spacer Coupling - Double Engagment
- KGH10 : Double Engagmen - Horizontal Sliding Coupling
- KGH20 : Single Engagmen - Horizontal Sliding Coupling

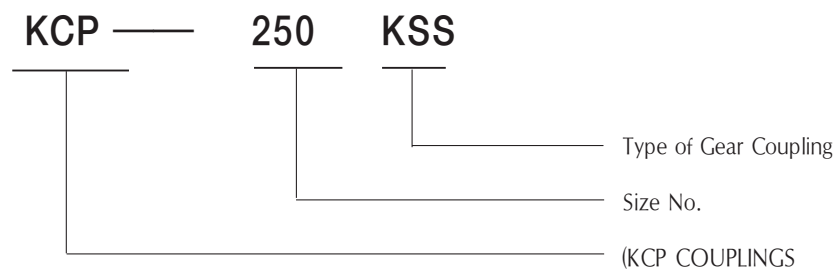

- KSS : Double Engagment Coupling
- KSE : Single Engagement Coupling
- KCC : Double Engagement Coupling - Large type
- KCE : Single Engagement Coupling - Large type

7. Instruction for Installation

1. Small Size(up to size 60)

Hub bore and keyway must be machined accurately. During the key-fit to the shaft and the hub, be careful with the oil leakage.

- ① Clean all parts, Grease the crowned gear teeth and O-Ring.
Put O-Ring onto the shafts.
- ② Place the flanged sleeves on the shafts and mount the hubs.
- ③ Using a spacer bar, make the gap between the hubs equal to the normal gap specified.
- ④ Align the shaft with a strait bar by checking every 90° degree, referring to the table 3. Make it sure with a dial gauge not to exceed the offset limit.
- ⑤ Insert gasket between the flanged sleeves and fasten the bolts, positioning the lube plugo at 90°
- ⑥ Fill grease until overflowing at the open opposite Lub plug hole.

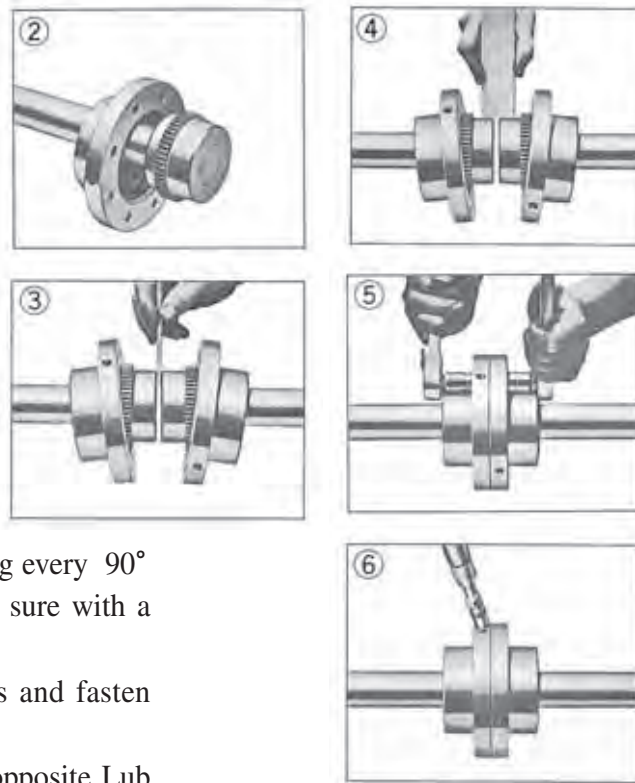

Fig. 3 Operating Limits of misalignment (mm)

Table 3

Size	10	15	20	25	30	35	40	45	50	55	60	70	80	90	100
Angular degree	0.125	0.125	0.25	0.25	0.3	0.3	0.3	0.3	0.3	0.3	0.3	0.3	0.4	0.4	0.4
Gap	3	3	3	4.5	4.5	6	6	8	8	8	8	9.5	10	13	13
Flange Bolt Torque(kg · cm)	96	320	480	960	960	1,650	1,650	1,650	2,070	2,070	2,070	2,980			

■ The life of coupling is reduced by excess of the OFFSET limit.

2. Large Size (over size 70)

Hub bore and Keyway must be machined accurately.

During the Key-Fit work, be careful Internal Gear not to make oil leakage.

- ① Clean all parts. Pack with grease and seals with grease before assembly.
- ② Place the side covers with sealing gaskets on the shafts before mounting the crown gears. Mount crown gears on their respective shafts. Mount Internal Gears with side cover gaskets.
- ③ Use a spacer bar equal into the gap. The difference in minimum and maximum measurements should not exceed the angular limit specified in table 3.
- ④ Align with a straightedge, rests squarely at every 90° as shown in photo Check with feelers. The tolerance should not exceed the offset limit specified in Table 3.
- ⑤ Insert gasket between flanges. Position Internal Gears with lube holes at about 90° and then fasten the bolt&nuts.
- ⑥ Remove all lube plugs and fill recommended grease into the coupling until excess flow through the opposite lub plug hole. And screw down plugs.

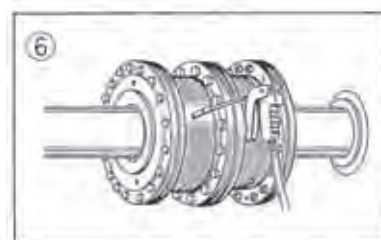
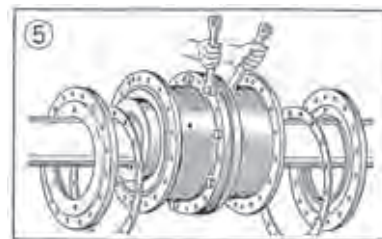
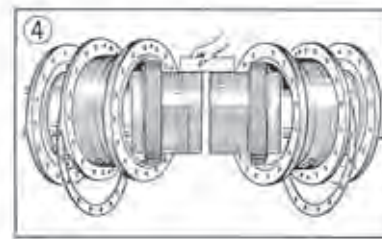
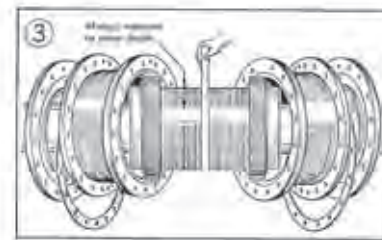
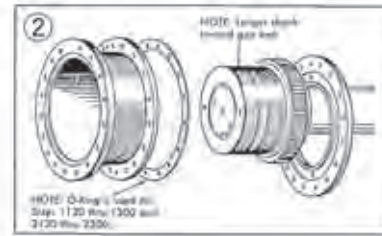

8. Selection of Puller Holes



표4 Table4

Size	BCD	Tap Size
20KG	89	M8
25KG	112	M10
30KG	128	M10
35KG	152	M12
40KG	181	M16
45KG	200	M16
50KG	216	M20
55KG	238	M20
60KG	268	M20
70KG	305	M24
80KG	318	M24
90KG	356	M30
100KG	394	M30
110KG	426	M30
120KG	498	M30

9. Lubrication and Handling

Information of the adequate lubricant for good performance and long life.

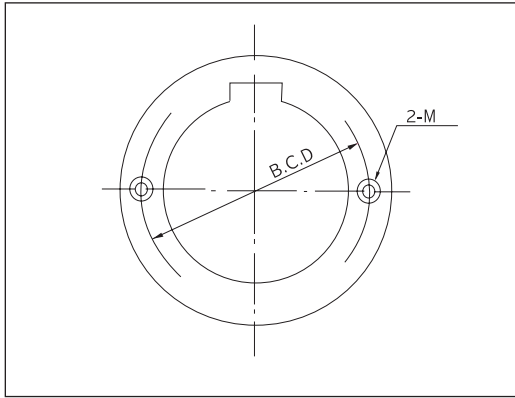
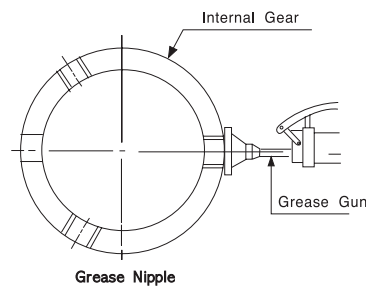

1. Lubricant

- ① Grease the Internal gear teeth and crown gear teeth, and fill enough lubricant Grease.
- ② Lub weight - Refer to "Dimensions Table" on page30.
- ③ Supplement and Replacement;
Add grease every moth or every 240~250 hours operating.
Renew all the contaminated grease every 3 months or every 4,000 hours operating

④ Selection

Allowable temperature of grease is from -17°C to 70°C . Refer to the table 6 that shows the coupling RPM allowed for the listed grease.

Table 5

Company	Oil	Grease # 1	Grease # 0
Gulf Oil Corp.		Gulfcrown Grease EP #1	Gulfcrown Grease EP #0
Shell Oil Corp.		Alvania Grease EP #1	Alvania Grease EP-RO
Texaco Inc.		Multifak EP - 1	Multifak EP - 0
Mobil Oil Corp.		Mobilux EP - 1	Mobilux EP - 0

■ NOTE : Lubricants listed in this manual are typical products.

"Why compete against your supplier when you can be our partner"

2. Lubricant Filling

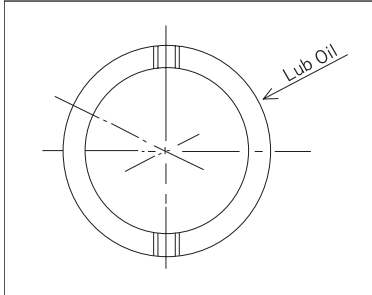

- ① Place the Lub plug holes × 2EA horizontal level. Fill up Lubricant until it overflows from the opposite hole.
- ② Supplement every month, or 240-250 hours operating.
- ③ Replacement completely all the contaminated lubricant, every 3 months or every 4,000 hours operating.

3. Selection of Lubricant

Table 6

Company		Shell	Mobil	Michang	Buhmwoo	Gulf	Fujikosan Nipponkoju	Houghton	Hanil		Caltex
CST 40°C	CST 40°C	omala 68	Mobilgear 626	Pio Gear EP 68	Buhmwoo Gearlube BG-68	Gulf EP Lubricant R 68	Hirax ME GO 300	MP Gear Oil 68	Nico Gear SP 68	Daphne CE compound 68C	Meropa Lubricant 68
100	465	omala 68		Pio Gear EP 68	Buhmwoo Gearlube BG-100	Gulf EP Lubricant HD 100	Hirax ME GO 500	MP Gear Oil 100	Nico Gear SP 100	Daphne CE compound 100S	Meropa Lubricant 100
150	700	omala 150	Mobilgear 629	Pio Gear EP 150	Buhmwoo Gearlube BG-150	Gulf EP Lubricant R150, HD150	Hirax ME GO 700	MP Gear Oil 150	Nico Gear SP 150	Daphne CE compound 150S	Meropa Lubricant 150, Synthetic Gear Lube
150	700	omala 220	Mobilgear 630	Pio Gear EP 220	Buhmwoo Gearlube BG-220	Gulf EP Lubricant R220, HD220	Hirax ME GO 1000	MP Gear Oil 220	Nico Gear SP 220	Daphne CE compound 220S	Meropa Lubricant 220
320	1500	omala 320	Mobilgear 632	Pio Gear EP 320	Buhmwoo Gearlube BG-320	Gulf EP Lubricant R320, HD320	Hirax ME GO 1500	MP Gear Oil 320	Nico Gear SP 320	Daphne CE compound 320S	Meropa Lubricant 320

■ Aboves are sample products.

Type G20, (Double Gear) Gear Coupling - AGMA Type

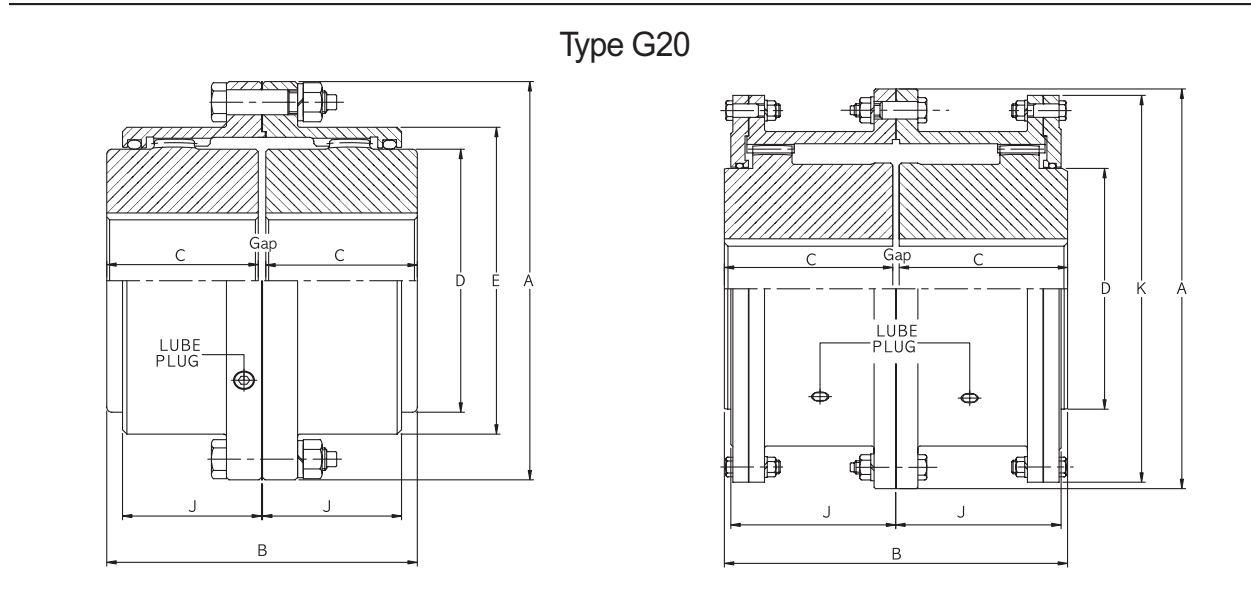

Size	Type G20 Standard Flanged Sleeve							Dimension(inch)						
	HP per 100 rpm	Torque Rating (lb-in)	Allow Speed rpm	Max bore da	Min bore da	Cplg Wt(lb) G20	Lube wf lb	A	B	C	D	E	J	Gap
1010G	16	10,080	8,000	1,875	50	10	.09	4.56	3.50	1.69	2.70	3.30	1.53	.125
1015G	33	20,790	6,500	2,375	75	20	.16	6.00	4.00	1.94	3.40	4.14	1.88	.125
1020G	60	37,800	5,600	2,875	1.00	35	.25	7.00	5.00	2.44	4.14	4.98	2.34	.125
1025G	105	66,150	5,000	3,625	1.25	65	.50	8.38	6.25	3.03	5.14	6.10	2.82	.188
1030G	170	107,100	4,400	4,125	1.50	95	.80	9.44	7.37	3.59	6.00	7.10	3.30	.188
1035G	260	163,800	3,900	4,875	2.00	150	1.20	11.00	8.63	4.19	7.00	8.32	3.84	.250
1040G	430	270,900	3,600	5,750	2.50	215	2.00	12.50	9.75	4.75	8.25	9.66	4.38	.250
1045G	590	371,700	3,200	6,750	3.00	300	2.30	13.62	10.93	5.31	9.25	10.79	4.84	.312
1050G	795	500,900	2,900	7,375	3.50	420	3.90	15.31	12.37	6.03	10.00	12.04	5.54	.312
1055G	1,040	655,200	2,650	8,250	4.00	550	4.90	16.75	13.56	6.62	11.00	13.16	6.22	.312
1060G	1,270	800,100	2,450	9,125	4.50	675	7.00	18.00	15.13	7.41	12.00	14.41	6.66	.312
1070G	1,900	1,197,000	2,150	10,875	5.00	1070	9.60	20.75	17.75	8.69	14.00	16.73	7.70	.375

Size	Type G20 Standard Flanged Sleeve							Dimension(inch)						
	Torque Rating lb-in(millions)		Allow Speed rpm	Max bore da	Min bore da	Cplg Wt(lb) G20	Lube wf lb	A	B	C	D	J	K	Gap
	1000 Series	2000 Series												
1080G	1,506	2,070	1,750	10.50	4.000	1150	21	23.25	20.02	9.82	14.00	9.56	22.50	.375
1090G	1,997	2,791	1,550	11.25	4.500	2170	27	26.00	22.26	10.88	15.50	10.44	25.25	.500
1100G	2,747	3,919	1,450	12.75	5.000	2870	33	28.00	24.50	12.00	17.50	11.56	27.50	.500
1110G	3,654	5,393	1,330	14.00	5.500	3700	39	30.50	26.74	13.12	19.50	12.69	29.50	.500
1120G	4,914	6,880	1,200	15.25	6.000	4660	46	33.00	28.26	13.88	21.50	13.44	32.50	.500